

**TOP FLANGED
TWO WAY STAINLESS STEEL BALL VALVE**



CREATIVE • INNOVATION • PROCESS



SKU:1587



Scan me

TOP FLANGED TWO WAY STAINLESS STEEL BALL VALVE

Description

Investment cast 3-piece full port stainless steel body/ball for unrestricted flow and minimum pressure loss. Adjustable live loaded stem seal packing helps compensate for wear, pressure or temperature fluctuations, extending the cycle life of the valve. Blow-out proof stem. Valve body held together with bolts for easy maintenance.

Features

- Full port, 1/4"~4" (DN8~DN100)
- W.P.:100WOG (PN63)
- W.T.: -20°C~180 °C
- Investment casting
- Blow-out proof stem
- Live-loading design
- Anti-static device(option)
- Locking device handle
- ISO 5211 Direct mounting pad
- Automation accessories(option)
- Thread type:ASME B1.20.1(NPT), DIN 259 / DIN 2999, BS 21 ISO 288-1, ISO 7-1
- Socket weld type : ASME B16. 11& DIN3239 part2
- Butt weld type : ASME B16.25 & DIN3239 part1

Application

Stainless steel ball valves with RTFE/Viton seals are typically used for on-off control of water, air, oil, vacuum and other media compatible with the materials of construction. Unique 3-piece investment cast bolted body design offers the advantage of a swing-out body for easy inline maintenance. Valves can be direct mounted to air or electric actuators using the standard ISO5211 mounting pad, eliminating the need for extra mounting brackets and couplings. Suitable for vacuum service up to 736 mmHg (29inHg)

Operation

Turning the hand lever one quarter-turn (90°) rotates the ball from closed to the open position. A locking device allows for pad locking the valve in either the open or closed position for safety lockout applications. The valve is actuator ready with standard ISO5211 mounting pad and square output shaft.

Options

- Air Actuators
- Electric Actuators
- Gear Box

Dimensions

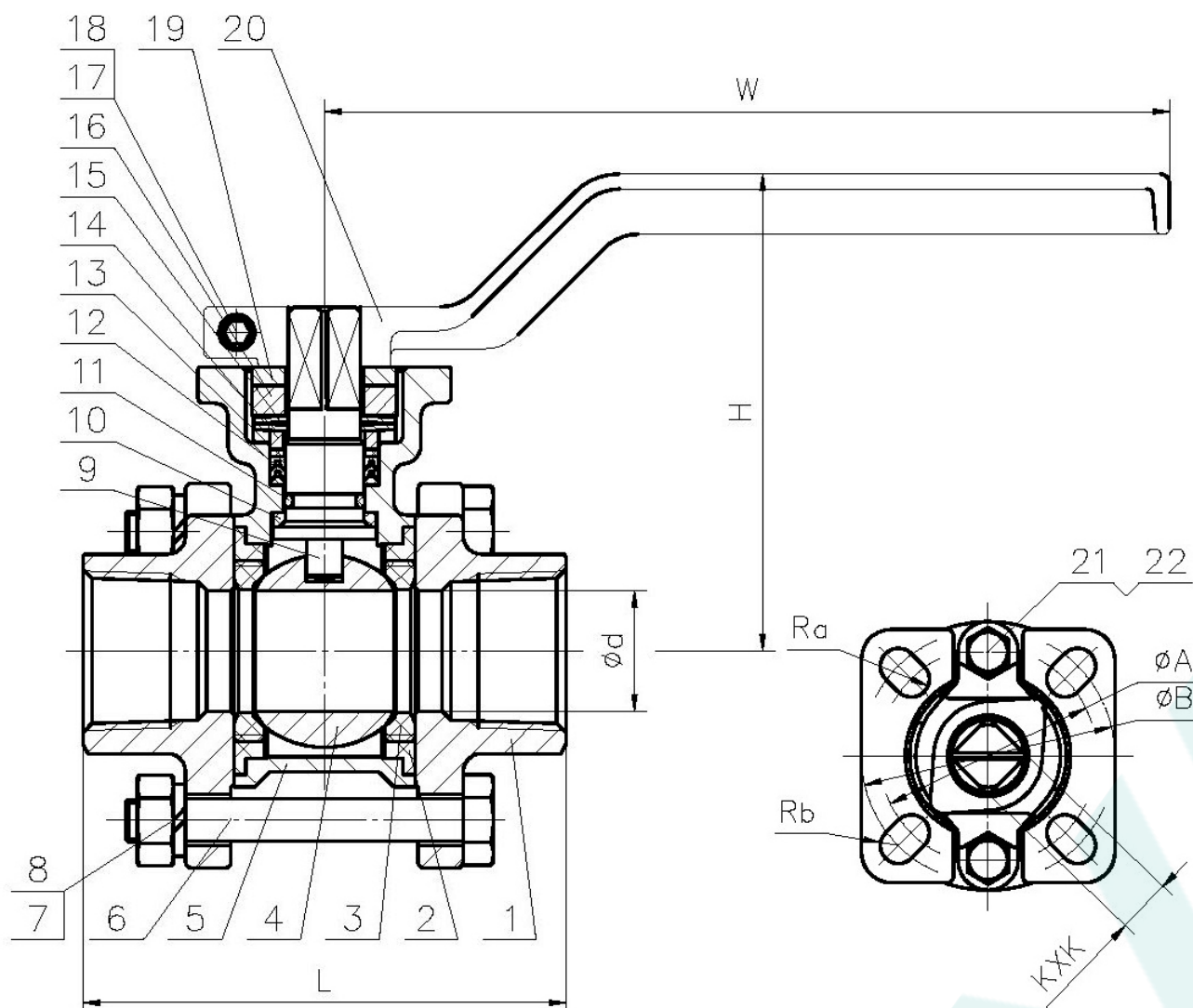

ITEM	PARTS	MATERIAL		
		WCB	CF8	CF8M
1	BONNET	WCB	CF8	CF8M
2	GASKET	PTEE		
3	SEAT	PTPE		
4	BALL	304	304	316
5	BODY	WCB	CF8	CF8M
6	BOLT	304		
7	SPRING WASHER	304		
8	NUT	304		
9	STEM	304	304	316
10	STEM WASHER	PTFE+25% GF		
11	O RING	FPM		
12	PACKING	PTFE		
13	WEAR WASHER	PTFE+25% GF		
14	GLAND	304		
15	DISC SPRING	304		
16	PACKING GLAND	CF8		
17	HEX SOCKET BOLT	304		
18	NUT	304		
19	STOPPER	304		
20	HANDLE	201		
21	BOLT	304		
22	NUT	304		

SIZE	1/4"	3/8"	1/2"	3/4"	1"	1 1/4"	1 1/2"	2"	2 1/2"	3"	4"
d	10	12	15	20	25	32	38	50	65	80	100
L	68	68	64	73	80	95	105	125	168	194	248
H	74	74	74	79	90	96	108	116	140	153	175
W	140	140	140	140	170	170	200	200	300	300	300
KXK	9X9	9X9	9X9	9X9	11X11	11X11	14X14	14X14	17X17	17X17	17X17
A	36	36	36	36	42	42	50	50	70	70	70
B	42	42	42	42	50	50	70	70	102	102	102
a	3	3	3	3	3	3	3.5	3.5	4.5	4.5	4.5
b	3	3	3	3	3.5	3.5	4.5	4.5	5.5	5.5	5.5